



ORDER FORM

➤ MP-RC5

**SLOPE MOUNT ROOF CURB
SHOP LOCATED, SHINGLE TYPE, FACTORY INSTALLED
CORRUGATION**

Please submit the following form and a Metallic Products representative will contact you about your order.

CUSTOMER NAME: _____

COMPANY (if applicable): _____

WILL CALL Phone Number (Req'd): _____

SHIP TO: _____ ZIP (Req'd): _____

ORDER NUMBER (if applicable): _____

JOB Reference (if applicable): _____

ORDER DATE (MM/DD/YY): _____ DUE DATE (MM/DD/YY): _____

QUANTITY: _____

➤ STANDARD FEATURES

- 16-gauge Galvanized
- Corners mitered and welded watertight
- Welds prime painted after fabrication
- Additional reinforcing when specified
- Water diverter
- 6" minimum height on ridge side
- 1-1/2" – 3# density insulation when specified

➤ ADDED OPTIONS

1. _____
2. _____
3. _____

MATCH ROOF PANEL: _____

ROOF PITCH: _____



PLEASE SEND COMPLETED FORM TO YOUR METALLIC PRODUCTS REPRESENTATIVE. Questions? Call us at 800.356.7746 or email sales@mpvent.com.



ORDER FORM

➤ **MP-RC5**

**SLOPE MOUNT ROOF CURB
SHOP LOCATED, SHINGLE TYPE, FACTORY INSTALLED
CORRUGATION**

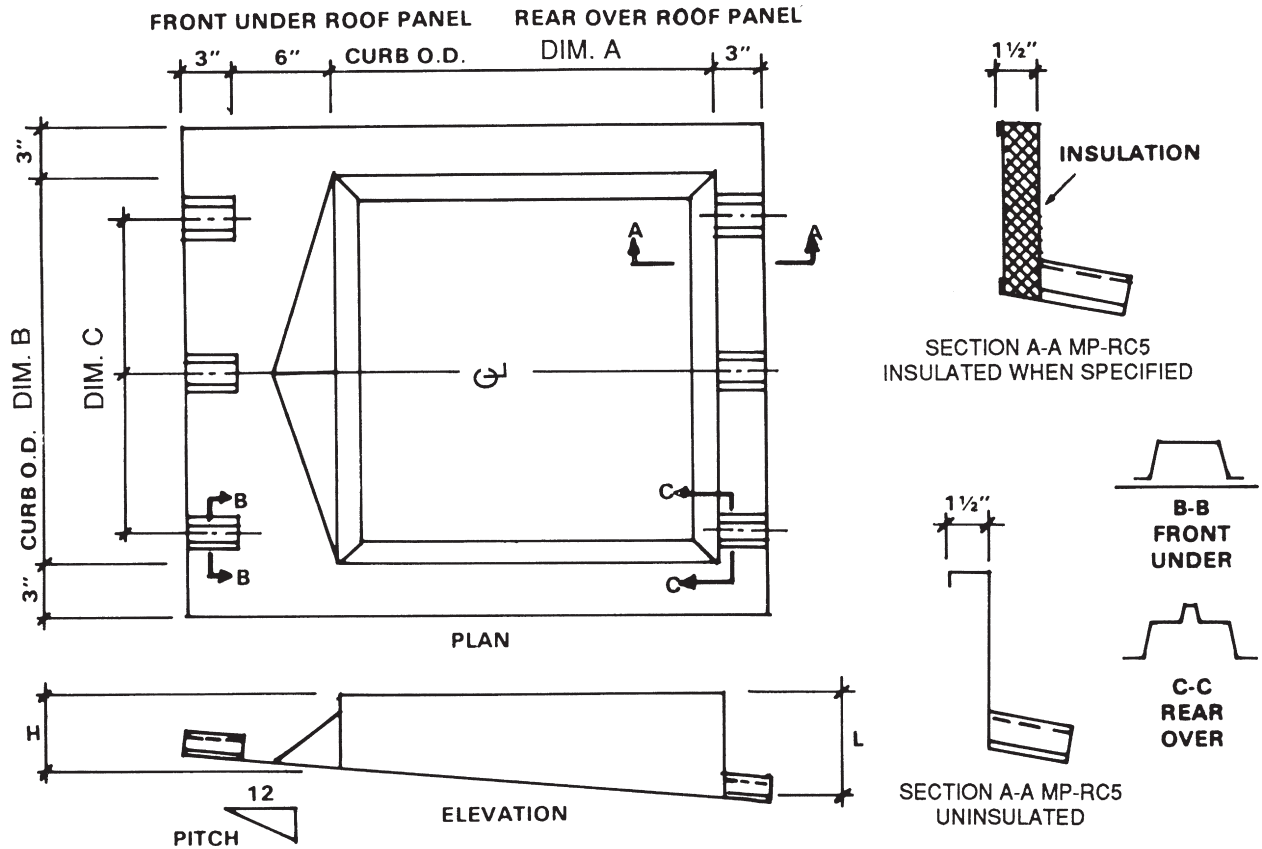

NO. REQ'D	DIM. A	DIM. B	DIM. C	H	L	TAG DESCRIPTION

➤ **SUBMIT FORM**



PLEASE SEND COMPLETED FORM TO YOUR METALLIC PRODUCTS REPRESENTATIVE. Questions? Call us at 800.356.7746 or email sales@mpvent.com.

