

Customer: _____

 Ship To: _____

 Order No.: _____
 Job No.: _____
 Order Date: _____
 Due Date: _____

Metallic Products
RIDGE MOUNT ROOF CURB
No Corrugation
MP-RC3

- STANDARD FEATURES*
1. 16 gauge galvanized steel shell and baseplate
 2. Corners mitered and welded watertight
 3. Welds prime painted after fabrication
 4. Internal angle reinforcing when specified
 5. Water diverter angle
 6. 6" minimum height on ridge side
 7. 1-1/2" – 3# density insulation when specified

- ADDED OPTIONS*
- 1.
 - 2.
 - 3.

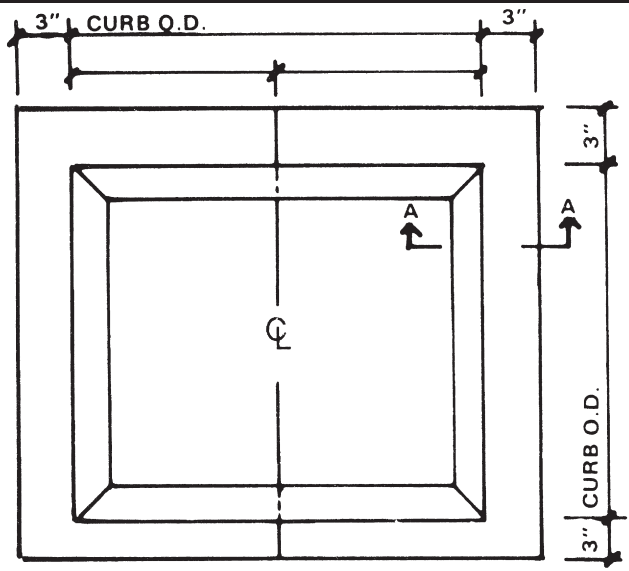

PLAN

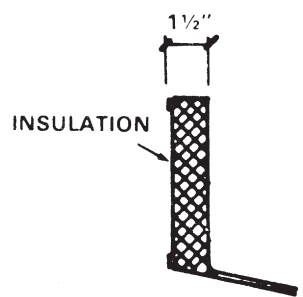

SECTION A-A MP-RC3
 INSULATED WHEN SPECIFIED

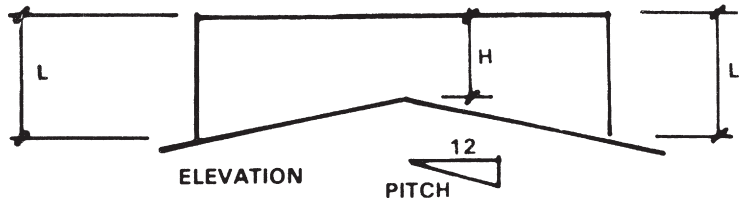

ELEVATION

PITCH



SECTION A-A MP-RC3
 UNINSULATED

NO. REQ'D	O.D. DIM.	H	L	TAG DESCRIPTION



INSTALLATION INSTRUCTIONS for MP-RC3

RIDGE MOUNT ROOF CURBS

To Be Installed Beneath Roof Deck

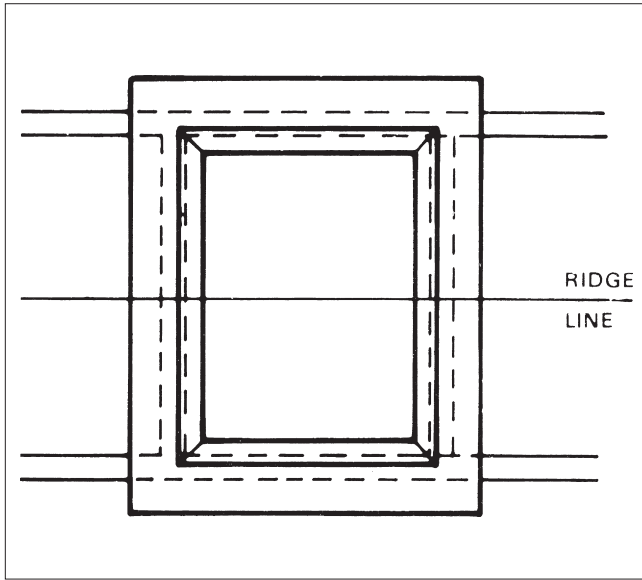

- A.
1. After building framing is complete, locate roof opening and install support framing for roof curb and equipment loads.
 2. Set and secure roof curb in place on support framing. At least two parallel curb walls must be on support framing. Loads shall not be supported by a cantilever section exceeding 1' in length.

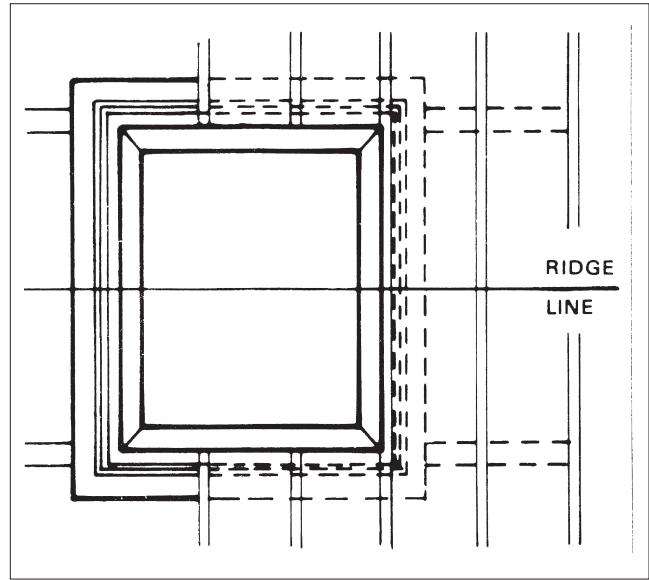

- B.
3. Cut roof panels to fit snugly around curb walls.
 4. Apply a wide band of tape caulk to top side of curb flanges.
 5. Install and seal closure strips as required. Press roof panels into position.

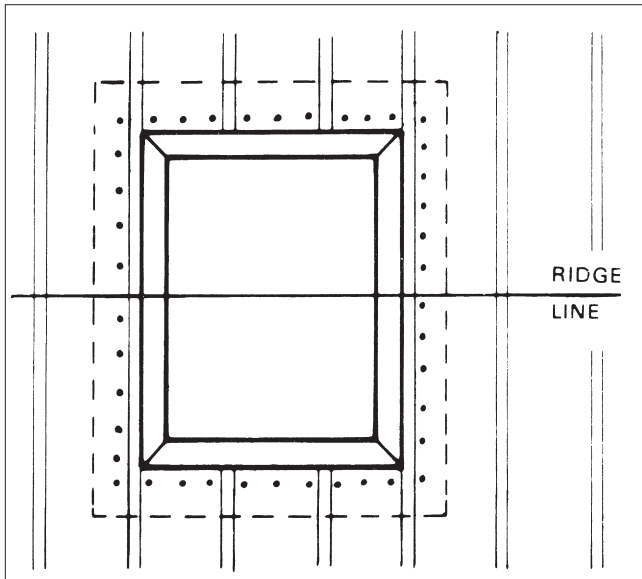

- C.
6. Fasten roof panel through curb flanges to support steel using suitable fasteners compatible with roof system. A minimum of four fasteners per side spaced on 3" centers or less as roof system permits. Fasteners should withstand a minimum pullout force of 150# each.

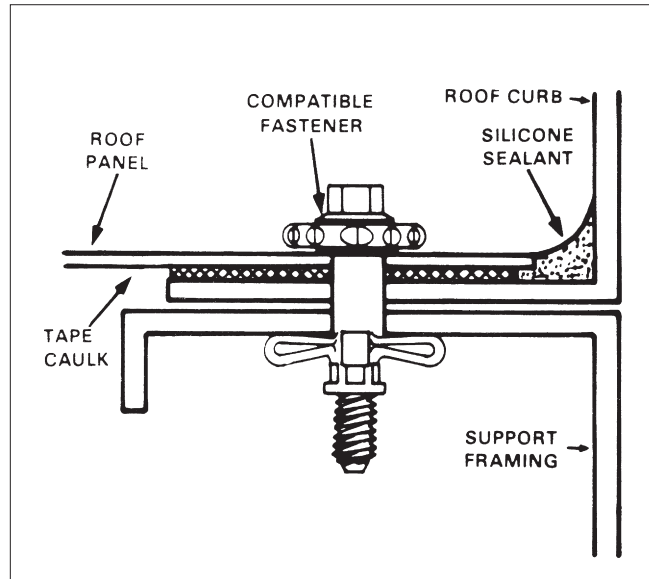

- D.
7. Inspect installation and fasteners. Apply silicone sealant to seal seams around all sides of curb to assure a water-tight seal.
 8. Apply a closed cell neoprene strip to top rail of roof curb before setting a rooftop unit. Equipment should be fastened directly to curb wall using compatible fasteners.

**Return to Roof
Curb Spec. Page**